



# 90° Offset Heads and Fixture Accessories



DIATEST Offset Heads deflect travel motion by 90° and have a travel range of 4.5mm or .177 in. Their compact size and standardized companion dimensions make them a useful accessory in fixture building and offer a wide range of application in gauging fixtures and measuring machines; in shape gauges and locating gauges, e.g. to measure roundness, cylinder shape, or spacing; in machine tools, e.g. for dial indicated carriage stop; in fact, in all instances where travel motion has to be deflected.

The uniform connecting thread "X" of M6 x 0.75 ensures that all system parts can be readily joined and interchanged.

## 1—90° Offset Heads

Travel Motion Offset by 90°  
Travel Range 4.5 mm or .177 inch  
Stem O.D.: 8 mm—0.01 (.31496"—.0004)  
Stem Lengths available:

L = 5 mm (.197") 10 mm (.394")  
15 mm (.591") 20 mm (.787")  
25 mm (.984") 40 mm (1.575")  
60 mm (2.362")

Transfer Spindle O.D.: 4 mm—0.01 (.15748"—.0004)  
Contact Point Thread "Y": M2.5—6H  
Other Stem Lengths "L" and other  
Contact Point Threads "Y": special, on request

### 1.1 Offset Head Model UK-L

Length of Transfer Spindle: 5 to 9.5 mm = 4.5 mm travel  
(.197" to .374" = .177" travel)

Accessory parts clamp to exposed spindle portion.

### 1.2 Offset Head Model UK-K

Length of Transfer Spindle: 0 to 4.5 mm = 4.5 mm travel  
(0 to .177" = .177" travel)

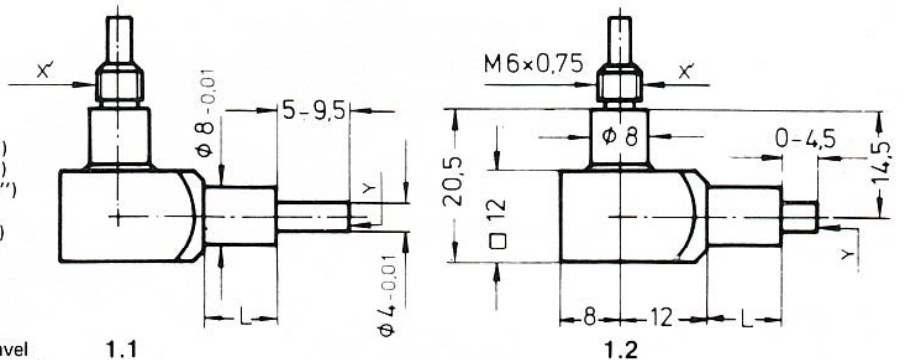

1.1

1.2

## 2—Dial Gauge Holders

Take dial indicators, micro comparators, or electronic probes, having a stem diameter of 8 mm h6, but see NOTE.

2.1 Dial Gauge Holder O.D. 10 mm (.394 in.)  
O.A.L. 51 mm (2.008 in.)

2.2 Short Dial Gauge Holder  
O.A.L. 32 mm (1.26 in.)

2.3 Dial Gauge Holders O.D. 10 mm (.394 in.)  
material temperature stabilized  
Available O.A.L.: L = 100 mm (3.94")  
150 mm (5.9") 200 mm (7.8") 290 mm (11.4")

NOTE—Not Illustrated:  
Dial Gauge Holder 3/8"  
O.A.L. 51 mm (2.008") with 3/8" (9.525 mm) collet

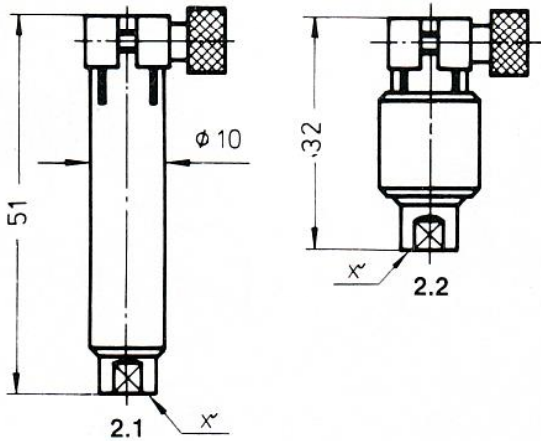

2.1

2.2

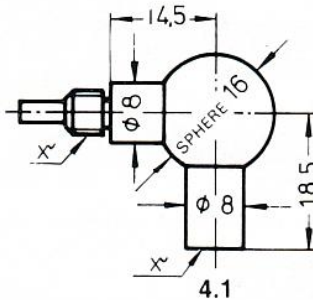

4.1

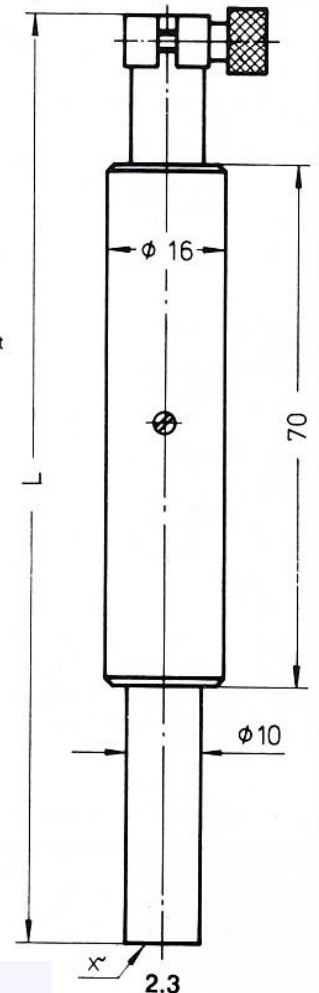

2.3

4.1 Right Angle Attachment  
Permits "double-bend" (90°—90°) offset  
Screws onto offset head or extension O.D. 8 mm

4.2 Double Clamp  
I.D. 8 mm (.315") x O.A.L. 20 mm (.787")  
Securely holds two joined parts, e.g. as in 4.1,  
and prevents them from twisting in threaded  
joint.

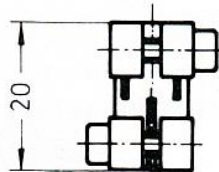

4.2

Jean-Louis MENEGON - Représentant & conseiller Sud Ouest

tél: 06.76.08.96.83 - mail: [jlouismenegon@aol.com](mailto:jlouismenegon@aol.com) - site web: [www.menegon-metrologie.com](http://www.menegon-metrologie.com)

All dimensions in drawings are shown in millimeters. Convert to inches by multiplying by .03937. Thread "X" = M6 x 0.75. Thread "Y" = M2.5—6H.

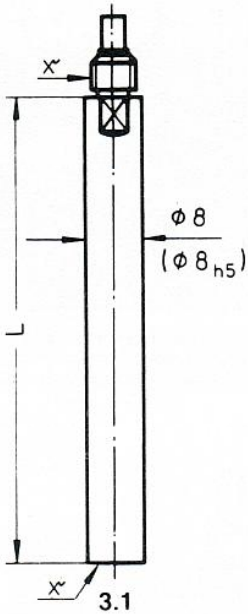

### 3 – Extensions

Transfer travel motion between system parts, e.g. between offset heads and dial gauge holders

#### 3.1 Extensions O.D. 8 mm (.315 in.)

Available Lengths: L = 20 mm (.787") 30 mm (1.181")  
 40 mm (1.575") 50 mm (1.97")  
 64 mm (2.52") 125 mm (4.92")  
 250 mm (9.84") 500 mm (19.68")  
 750 mm (29.53") 1000 mm (39.37")

Extensions of L = 125 mm and over: material temperature stabilized

#### Extensions O.D. 8 mm h5 (.31496" – .00024)

Hard chrome plated for use as rotating parts, e.g. in shape or locating gauges  
 Available in L = 64 mm (2.52")  
 125 mm (4.92") material temperature stabilized

#### 3.2 Extension: O.D. 10 mm (.394")

Material temperature stabilized  
 Available in L = 240 mm (9.45") 500 mm (19.68") 750 mm (29.53")  
 1000 mm (39.37")

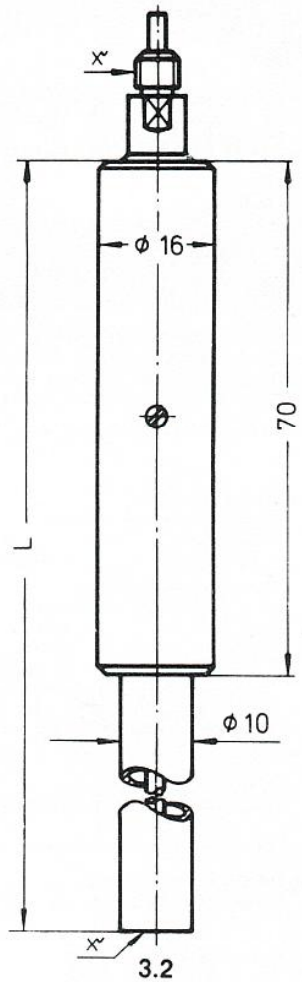

### 5 – Offset Heads Model ZM

Deflect travel motion by 90° in confined areas. Useful component in shape, spacing, and locating gauges.

#### 5.1 Model ZM-10

Contact point: solid carbide ball, dia. 2.5 mm (.098")  
 Dimension "A" = 4.6 mm (.181") + travel of 2.5 mm (.098")  
 Dimension "B" = 14 to 15 mm (.551 to .590") travel dependent

#### Offset Head Models ZM-13 through ZM-41

Spherical contact tip: solid carbide, radius R = 4 mm (.157")

#### 5.2 Model ZM-13: dim. "A" = 6.1 mm (.240") + travel of 3 mm (.118")

Model ZM-17: dim. "A" = 8.1 mm (.319") + travel of 3 mm (.118")

#### 5.3 Model ZM-21: dim. "A" = 10.1 mm (.398") + travel of 3 mm (.118")

Model ZM-25: dim. "A" = 12.1 mm (.476") + travel of 3 mm (.118")

Model ZM-29: dim. "A" = 14.1 mm (.555") + travel of 3 mm (.118")

Model ZM-33: dim. "A" = 16.1 mm (.634") + travel of 4.5 mm (.177")

Model ZM-37: dim. "A" = 18.1 mm (.713") + travel of 4.5 mm (.177")

Model ZM-41: dim. "A" = 20.1 mm (.791") + travel of 4.5 mm (.177")

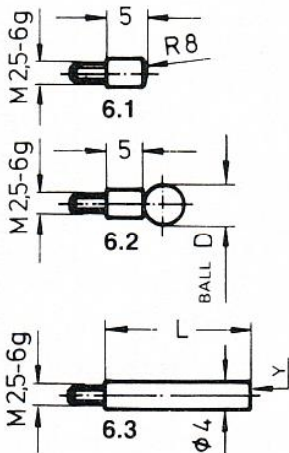
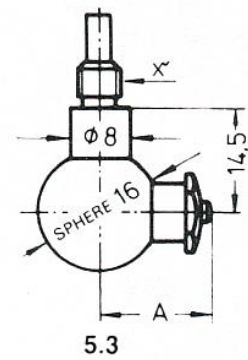
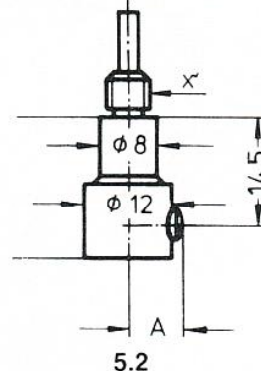
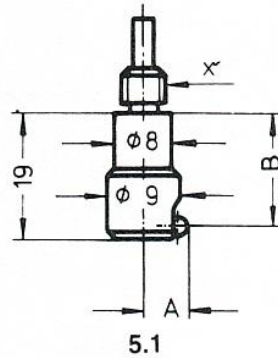

### 6 – Gauging Inserts

Threaded M2.5–6g (M2.6 or others: special, on request)

#### 6.1 Contact Point

O.D. 4 mm (.157") x O.A.L. 5 mm (.197")  
 Spherical contact tip: solid carbide, radius R = 8 mm (.315")

#### 6.2 Ball Contact Points

Spindle O.D. 4 mm (.157") x 5 mm (.197") long  
 Furnished with solid carbide balls ±0.001 mm (±000040"), hardness 1,600 Vickers  
 Available ball diameters: 0.500 0.501 0.502 0.503 etc. to 15.000 mm, in increments of 0.001 mm.  
 Inch sizes also available.  
 Other spindle lengths: special, on request.

#### 6.3 Dial Gauge Spindle Extensions

O.D. 4 mm (.157")  
 Available in lengths "L": 10 mm (.394") 20 mm (.787") 30 mm (1.18") to 100 mm (3.94") in increments of 10 mm (.394")  
 Other spindle lengths: special, on request.

**Jean Louis MENEGON**

Représentant et Conseiller  
 Région Sud Ouest

Tel : 06 76 08 96 83

email: [jlouismenegon@aol.com](mailto:jlouismenegon@aol.com)

Visiter le site Web:

[www.menegon-metrologie.com](http://www.menegon-metrologie.com)